

Bellini

INSTALLATION & OPERATION INSTRUCTIONS



**60cm 5 Function Oven & 60cm
Electric Cooktop**

BPT150EE (NZ Only)

Bellini

INSTALLATION & OPERATION INSTRUCTIONS



60cm Electric Cooktop

Model No.

BST601X-F FINELINE: 267897 NZ Only

BST601X

INCLUDED IN BUILDERS PACK:

- BPT150EE – 5103598 NZ Only

Thank you

Thank you for choosing Bellini Appliances.

All Bellini appliances carry a 3 year In Home warranty,
be sure to retain your installation and user manual and
receipt.

For all warranty and technical queries please contact

Australia 1300 373 199

New Zealand 0800 764 912

Content

Safety instructions-----	1
Product description-----	4
Installation-----	5
How to Use your Cooktop-----	8
Maintenance and cleaning -----	9
Warranty-----	11

All electrical work/repairs must be carried out by a suitable and authorised electrician or service agent.

Important Safeguards

When using electrical appliances, in order to reduce the risk of fire, electric shock and/or injury, these basic safety precautions should always be followed:

For Your Safety

Read all instructions carefully, even if you are quite familiar with the appliance.

- This appliance is not intended for use by persons (including children) with reduced physical, sensory and mental capabilities, or lack of experience and knowledge, unless they have been given supervision or instruction concerning use of the appliance by a person responsible for their safety.
- Young children should be supervised to ensure they do not play with the appliance.
- **WARNING:** Accessible parts may become hot during use. To avoid burns young children should be kept away.
- If it is necessary for younger family members to be in the kitchen, please ensure that they are kept under close supervision at all times.
- Take care not to burn hands on upper elements when removing items from the cooker.
- Do not touch hot surfaces.
- **CAUTION:** The temperature of the door or the outer surface may be high when the appliance is in operation.
- Use only on heat resistant surfaces.
- The appliance becomes hot during operation. Take care not to touch the hot parts inside the oven.
- **WARNING:** Ensure that the appliance is switched off before replacing the lamp to avoid the possibility of electric shock.
- In order to prevent accidental tipping of the appliance, for example by a child climbing onto the open oven door, the stabilising means must be installed. Refer to the instructions for installation.

NOTE: The adjacent furniture or the housing and all materials used in the installation must be able to withstand a minimum temperature rise of 85°C above ambient during periods of use. Certain types of vinyl or laminate kitchen furniture are particularly prone to heat damage or discolouration at temperatures below the above guidelines. Installing the appliance in contravention of this temperature limit or the placing of adjacent cabinet materials closer than 4mm to the appliance, will be at the liability of the owner.

NOTE: The minimum safety distance between the top of the cooktop and the underside of the rangehood must be 600mm.

- Allow the appliance to cool before cleaning.
- Do not use the appliance for anything other than its intended use. This product is intended for household use only.
- DO NOT MOVE appliance when switched on.
- Ensure the power cord does not touch the cooker housing when in use.
- Do not use outdoors.
- **WARNING:** If the surface is cracked, switch off the appliance to avoid the possibility of electric shock.
- This cooking range must be connected to the supply by a supply cord fitted with an appropriately rated plug that is compatible with the socket-outlet fitted to the final sub-circuit in the fixed wiring that is intended to supply this cooking range.
- Do not attempt to repair or disassemble the appliance.
- The appliance should not be covered or operated near or underneath flammable material such as curtains or drapes or other combustible materials when in operation.
- Do not operate in the presence of flammable or explosive materials.

- Do not operate any appliance with a damaged cord or plug.
- Do not allow electrical fittings or cables to be in contact with hot areas of the appliance.
- Do not use an extension cord with this appliance.
- Take care when opening and closing the door of the appliance.
- Don't move the cooker by pulling by the door and/or handle.
- Do not attempt to lift or move cooking appliances by pulling on any door or handle as this can cause damage.
- Don't store flammable materials, aerosols etc., in adjacent cabinets.
- Don't place flammable or plastic items on or near the hob and never place wet cloths etc., on the hob to dry.
- Don't store flammable items such as oven gloves, paper and similar items in the storage compartment.
- **Don't use the cooker for:**
 - Hanging towels and dish cloths etc., on the handles
 - Warming plates under the grill
 - Heating the kitchen
 - Drying
- Ensure that the appliance is switched off before replacing the lamp to avoid the possibility of electric shock.
- Do not place heavy objects on or lean on the oven door when open as this can cause damage to the hinging.
- Do not place pans or baking trays on the bottom of oven cavities or line with Aluminium Foil.
- NEVER INSERT A KNIFE OR ANY OTHER UTENSIL INTO THE COOKER. This may damage the mechanism and cause a safety hazard. Contact with elements could result in electrical shock.
- **Food Hygiene**
Ensure meat and poultry is thoroughly defrosted before cooking.
Check food is thoroughly cooked and is piping hot.
- Ensure that small items of household equipment, including connection leads, do not touch the hot oven or the hob as the insulation material of this equipment is usually not resistant to high temperatures.
- Do not allow the hob to get soiled and prevent liquids from boiling over onto the surface of the hob. Any spillages should be cleaned up as they happen.
- Do not place pans with a wet bottom on the warmed up heating zones as this can cause irreversible changes to the hob (irremovable stains).
- Do not switch on the hob until a pan has been placed on it.
- Do not put pans weighing over 15kg on the opened door of the oven and pans over 25kg on the hob.
- Do not use harsh cleaning agents or sharp metal objects to clean the doors as they can scratch the surface, which could then result in the glass cracking.
- Do not use the cooker in the event of a technical fault. Any faults must be fixed by an appropriately qualified and authorised person.
- In the event of any incident caused by a technical fault, disconnect the power and report the fault to the service centre to be repaired.
- The rules and provisions contained in this instruction manual should be strictly observed. Do not allow anybody who is not familiar with the contents of this instruction manual to operate the cooker.
- The cooker should not be cleaned using steam equipment.
- Any spillage should be removed from the hob lid before opening. The hob surface should be allowed to cool before closing the lid.
- Do not attempt to repair, modify, and disassemble the appliance. The use for any other purpose or in any other environment without the express agreement of the manufacture or its agent would invalidate any warranty or liability claim.

- This appliance complies with all current safety legislation, however the manufacture wish's to emphasise that compliance does not remove the fact that the appliance surfaces will become hot during use and retain heat after operation.
- We also advise that great care is taken during use and cleaning operations.
- Remove cardboard lids from food containers and replace with aluminum foil before placing in the appliance. When using aluminum foil, keep it from touching the heating elements.
- This appliance must be correctly installed by a suitably qualified person, strictly in accordance with the manufacturer's instructions. The manufacture declines any responsibility for injury or damage to persons or property as a result of improper use or installation of this appliance.
- Dispose of packaging properly keeping plastic bags away from babies and young children.

Compulsory Warning

If the supply cord is damaged, the cord must be replaced by the manufacturer, its service agent or similarly qualified persons in order to avoid a hazard.

This product has not been designed for any uses other than those specified in this booklet.

Save These Instructions

The manufacturer reserves the right to introduce changes which do not affect the operation of the appliance.

Features of Your Electric Cooktop

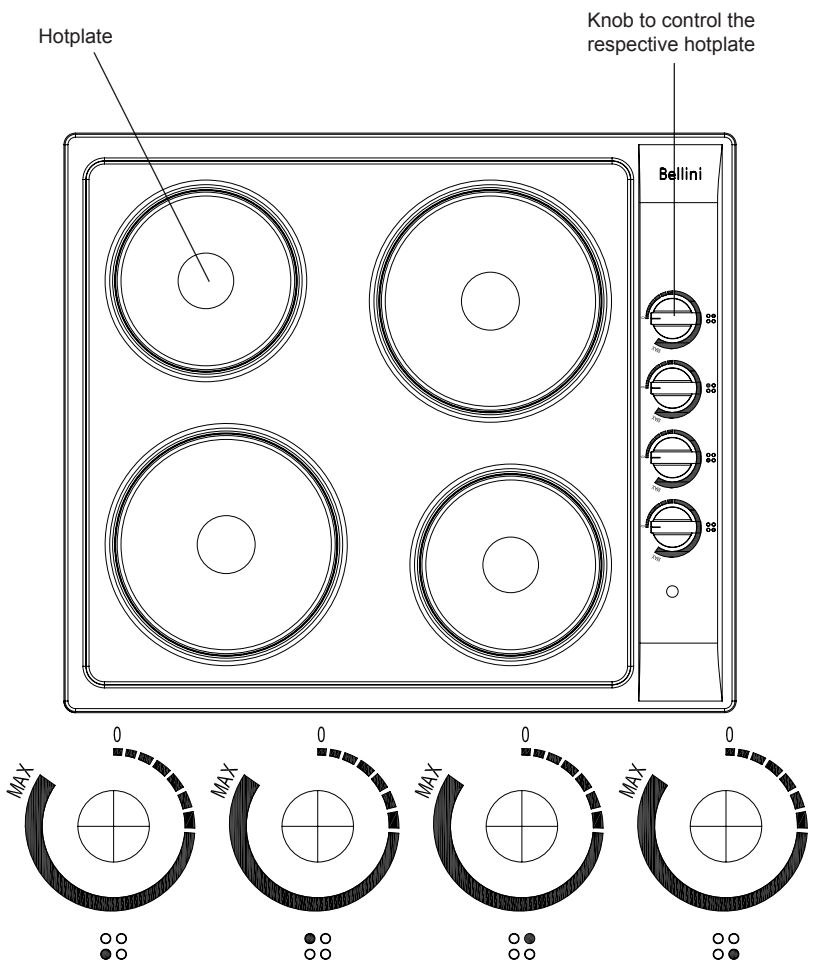

A marking to the bottom right of each control knob, indicates which hotplate it controls.

Getting to Know Your Cooktop

Congratulations on the purchase of your new Bellini appliance.

Before using your new cooktop, it is most important that you read and follow the instructions in this use and care booklet, even if you feel you are familiar with this type of appliance.

Your attention is drawn particularly to the section dealing with IMPORTANT SAFEGUARDS.

Find a safe and convenient place to keep this booklet handy for future reference.

This appliance has been designed to operate from a standard domestic power outlet. It is not intended for industrial or commercial use.

How to Save Energy

Using energy in a responsible way not only saves money but also helps the environment. So let's save energy! And this is how you can do it:

- Use proper pans for cooking. Pans with thick, flat bases can save up to 1/3 on electric energy. Remember to cover pans if possible otherwise you will use four times as much energy!
- Match the size of the saucepan to the surface of the heating plates. A saucepan should never be smaller than a heating plate.
- Do not uncover the pan too often (a watched pot never boils!).
- Do not install the cooktop in the direct vicinity of refrigerators/freezers. Otherwise energy consumption increases unnecessarily.

Installation

Positioning

This appliance must be correctly installed by a suitably qualified person.

To avoid damaging your appliance.

- Pans should be lifted on and off the hotplate surface and not dragged.
- Hotplates should not be switched on without cookware placed on them. Cookware should not be empty.



The adjacent furniture must be able to withstand a minimum temperature rise of 100°C above the ambient temperature of the room it is located in, during periods of use.

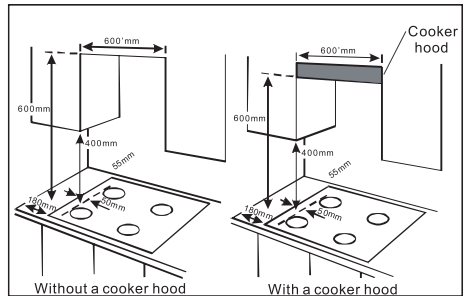

This appliance is to be built into a kitchen unit (depending on size) or 600 mm worktop, providing the following minimum distances are allowed:

- 600mm (minimum) between the hob surface and the underside of any horizontal surface above it.
- 50 mm clearance around the appliance and between the hob surface and any combustible materials.

Unpacking the appliance

When unpacking the appliance please check that the following items are contained within the packaging:

- 1 cooktop
- 1 Installation and instruction manual
- 4 Fixing screws
- 4 Clamps
- 1 Sealing strip

Installing the appliance

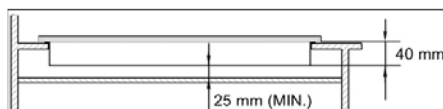
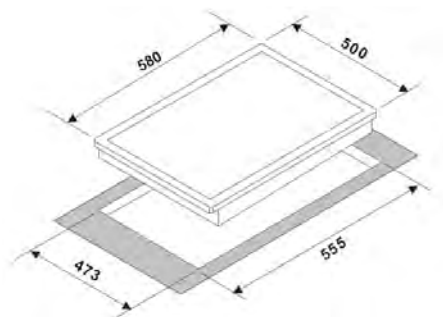

- Cut a hole in the worktop that corresponds with the drawings shown above.
- **IMPORTANT:** You must have a gap of at least 25 mm between the underneath of the appliance and any surface that is below it.

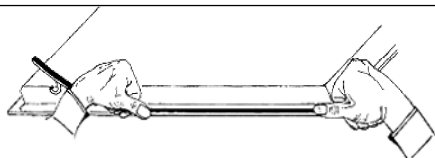

- Carefully turn the cooktop upside down and place it on a cushioned mat.
- Apply the sealing strip provided around the edge of the appliance.
- The protective covering must be removed from both sides.
- Do not leave a gap in the sealing agent or overlap the thickness.
- **IMPORTANT:** Do not use a silicon sealant to seal the appliance against the aperture. This will make it difficult to remove the hob from the aperture in future, particularly if it needs to be serviced.

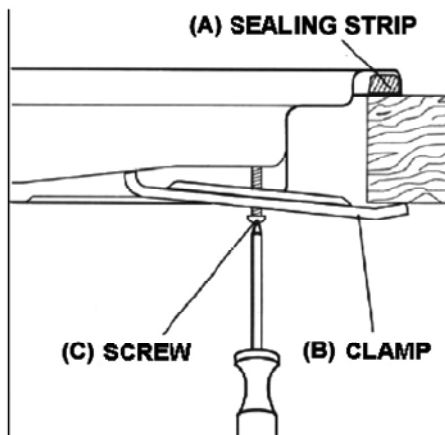

- Place the clamp (B) over the holes that match the size of the screws. There are one set of screw holes in each corner of the cooktop. Slightly tighten a screw (C) through the clamp (B) so that the clamp is attached to the cooktop, but so that you can still adjust the position of it.
- Carefully turn the cooktop back over and then gently lower it into the aperture hole that you have cut out.
- On the underneath of the cooktop, adjust the clamps into a position that is suitable for your worktop. Then fully tighten the screws (C) to secure the cooktop into position.

Electrical connection



This appliance must be installed by a qualified person.

Before connecting the appliance, make sure that the supply voltage marked on the rating plate corresponds with your mains supply voltage.

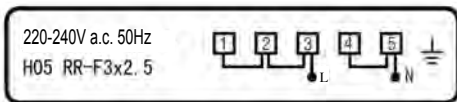

WARNING: THIS APPLIANCE MUST BE EARTHED.

Connecting the mains supply cable

- The mains terminal block is located on the underside of the hob and the terminals are accessible by removing the terminal block cover by removing the cover screw.
- The cable connections must be in accordance with the diagram located on the bottom of the hob.

Hard Wired Appliances :

When making the mains supply conductor connections to the terminal block within the terminal box , please ensure that minimum clearances are being maintained between individual conductors and conductors/connectors to the adjacent metal surfaces of the terminal box itself , where possible add heat shrink sleeves to any bare conductor end/connectors prior to securing.

Troubleshooting Guide

Problems	Possible Cause and solve
The hotplates are not functioning or will not switch on.	Check that the mains electrical supply to the appliance is correct and working. Check the mains fuse.
A humming sound is heard when a hotplate is selected.	This is normal; the sound will disappear when the hotplate heats up
The hotplates have become discoloured	This maybe caused by burnt on remnants of food. This will not affect the working of the appliance. However you should make sure that the cleaning instructions are being followed regularly.
Only two of the hotplates on my cooktop are working	You should recheck that the terminal screws are all fully tightened between the links.

IMPORTANT: If your appliance appears not to be operating correctly, then you should disconnect it from your mains supply and then contact the Service Department . DO NOT ATTEMPT TO REPAIR THE APPLIANCE BY YOURSELF.

How to Use Your Electric Cooktop

Product specification

Product dimensions: L: x W: x H(mm)	580x500x85
Aperture dimensions: L: x W: x H(mm)	473 x 555 x40
Product specifications:	1 x 2.00 kW + 1.30kW thermostatic plates (diameter 180 mm) 2 x 1.00 kW thermostatic plates (diameter 145 mm)
Electrical details	220-240 Vac 50 Hz 30 A (double pole switched fused outlet with 3mm contact gap) Max Rated Inputs: 5.30 kW Mains Supply Lead: 3 core x 2.5 mm_ (not supplied)

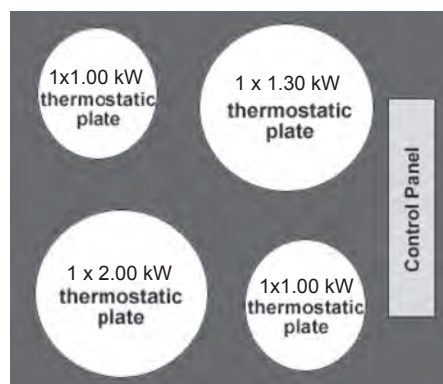

Plate layout

Before first use

IMPORTANT: You should clean the cooktop and hotplates. (See Cleaning and maintenance section).

- You should switch on one hotplate at a time, for 5 minutes at the maximum setting. This will help to eliminate any new smell that exists and evaporate any humidity that has formed on the heating elements during transit.

Control knobs

- All operations are performed by means of the 4 control knobs that can be found on the right hand side of the cooktop.
- The control knobs can be turned either clockwise or anti-clockwise to select a heating level. The numbers around the outside of each control knob indicates the power level that you have set the hotplate to.
- A marking to the bottom of each control knob, indicates which hotplate it controls.

Turning on a hotplate and setting a power level

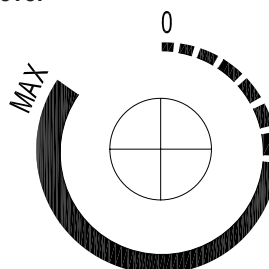

- Turn the control knob of the hotplate that you wish to cook on, clockwise or anticlockwise until it reaches the power level that you desire.
- When you have finished cooking, make sure that you turn the control knob anti-clockwise, to the 0 position.

Cooktop guidelines

- The first few times the cooktop is used, it may give off an acrid, burning smell. This smell will disappear completely with repeated use.
- The hotplates are fitted with cooking areas of different diameter and power.
- The positions where the heat will radiate from are clearly marked on the cooktop. The saucepans must be positioned exactly on these hotplates for efficient heating to occur. Pans should have the same diameter as the hotplate that they are being used on.
- You should not use saucepans with rough bottoms, as this can scratch the solid plates.
- Before use, make sure that the bottoms of the saucepans are clean and dry.
- When cold, the bottom of the pans should be slightly concave, as they expand when hot and lie flat on the surface of the hotplate. This will allow the heat to transfer more easily.
- Cover pans with a lid to permit cooking at a lower heat.
- Food or liquid that has high sugar content may damage the cooktop if it comes into contact with the hotplates. Any spillages should be wiped up immediately, however this may not prevent the hotplates from becoming damaged.
- **DO NOT USE THE HOTPLATE IF THE SURFACE BECOMES BROKEN OR CRACKED.**

Caution!

Large pots **MUST NOT** be placed over two or more hotplates as damage will more than likely occur.

Do not leave pans unattended on a hotplate.

Ensure the hotplates are clean. A soiled hotplate does not transfer all the heat.

Protect the hotplate against corrosion.

Switch off the hotplate before a pan is removed.

Cleaning Your Cooktop

Allow the cooktop to cool before cleaning.

- The hotplates should be cleaned after every use to avoid build up of food.
- If a major spillage occurs, wipe clean as soon as possible with a damp cloth.
- Do not immerse in water.
- **DO NOT** use spray-on or other cleaners as they may cause electrical damage. **DO NOT** use sharp utensils to clean.

Abrasive cleaners or sharp objects will damage the cooktop surface; you should clean it using water and a little washing up liquid.

Although it is easier to clean some deposits whilst the hotplates are still warm, you should take care not to burn yourself.

After each use

- Wipe the appliance over with a damp cloth and a little washing up liquid.
- Dry the appliance by rubbing the surface with a clean cloth.

Regular Inspections

Besides keeping the cooktop clean, you should:

- Carry out periodical maintenance.

Caution!

All repairs and regulatory activities should be carried out by the appropriate service centre or by an appropriately authorised fitter.

- Before using your electric cooktop, check each time that the base of the saucepan and the cooking zone are clean and dry.
- To save on energy consumption, always use pans with lids. When the boiling point is reached, it is best to turn the knob to the **LOW** position.
- Do not allow vinegar, coffee, milk, salted water, lemon or tomato juice to remain in contact with the enamelled surface of your cooktop for long periods of time.

- Never leave the hot plates on without pans on them or with empty pans. Switch on the hot plates after having set the pan in place.
- Switch off the heating element before removing the pan, Once switched off, the plates will remain warm for a while.
- Avoid using oversized pans that may radiate excessive heat and cause damage to surrounding surfaces.

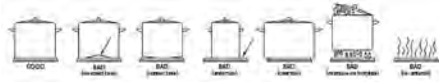

Cleaning Hints

To keep your electric cooktop in good condition, always allow it to cool down before attempting to clean.

Stainless steel surface

The stainless steel surface are to be cleaned only with a damp cloth and with a purpose made product from your local supermarket or hardware store, or a few drops of olive oil on a damp cloth.

Hot Plates

Weekly cleaning of frequently used hot plates is recommended to maintain their surface finish.

- Use a small amount of concentrated household detergent and a nylon scourer to remove all baked on grime. Wipe off with a damp cloth and dry with about 10 seconds of high temperature heat.
- Apply a hot plate protector to the cleaned hot plates such as Solid Hotplate Protector or lightly oil with olive oil while plate is still warm.
- The chrome element rings around the hot plates will change colour over time due the effect of the heat on the metal. The colour changes are dependant on the temperature levels and is common to all electric cooktops.

WARRANTY

- 1.1 In this warranty:
- 1.1.1 Australian Consumer Law means the law as set out in Schedule 2 of the Competition and Consumer Act 2010;
 - 1.1.2 **Company** means GSM Retail Australia Pty Ltd ABN 53 007 682 475 of 142-144 Fullarton Road, Rose Park SA 5067. Telephone 1300 373 199. Email admin@gsmretailgroup.com
 - 1.1.3 **Consumer** means a “consumer” as that term is defined in Section 3 of the Australian Consumer Law as the original purchaser of a Bellini product;
 - 1.1.4 **Consumer Guarantees** means the guarantees under the Australian Consumer Law;
 - 1.1.5 **You** means the Consumer.
- 1.2 Nothing in this warranty affects any person’s rights under the Australian Consumer Law. The benefits to any Consumer under this warranty are in addition to the rights and remedies available under any Consumer Guarantees.
- 1.3 Subject to the other clauses of this warranty, the Company warrants to the Consumer that the Bellini product will be free of manufacturing defects and will perform to the Company’s specifications.
- 1.4 The benefit of this warranty extends only to the Consumer as original purchaser of a Bellini product which is installed in a domestic household area.
- *The in Home warranty does not apply to Commercial and or industrial usage. *Please See 1.7.7 for additional information*
- 1.5 This warranty commences on the date of purchase of the Bellini product by the Consumer and continues for the benefit only of the Consumer until the expiry of three (3) year **(Warranty Period)**.
- 1.6 If within the Warranty Period a manufacturing defect is discovered in the Bellini product or it fails to perform to the Company’s specifications as a result of some defect in materials, components or workmanship (Defect) then the Company will, at its option, repair the Bellini product or supply a replacement Bellini product free of charge. A replacement Bellini product may differ from the original product purchased by the Consumer.
- 1.7 This warranty will not apply to any Bellini product:
- 1.7.1 Installed by any person other than a qualified tradesperson; or
 - 1.7.2 Subjected to misuse, neglect, negligence or accidental damage; or
 - 1.7.3 Operated in any way contrary to any operating or maintenance instructions; or
 - 1.7.4 Improperly handled, installed or maintained; or
 - 1.7.5 Altered or modified prior to or after installation; or
 - 1.7.6 Damaged directly or indirectly by power surges, electrical storm damage or connection to incorrect power supply
 - 1.7.7 Industrial and or Commercial usage is inclusive of staff areas in office/ shop environments, hotel/ motel or other similar accommodation or rental type properties including Bed and Breakfast establishments.

The Australian Consumer Law requires the inclusion of the following statement with this warranty:

Our goods come with guaranteed that cannot be excluded under the Australian Consumer Law. You are entitled to a replacement or refund for a major failure and for compensation for any other reasonably foreseeable loss or damage. You are also entitled to have the goods repaired or replaced if the goods fail to be of acceptable quality and the failure does not amount to a major failure.

**IN ORDER TO MAKE A CLAIM UNDER THIS WARRANTY THE CONSUMER
MUST CALL 1300 373 199 (AUSTRALIA) OR 0800 764 912
(NEW ZEALAND) TO CONNECT TO THE NEAREST AUTHORISED CENTRE**

- 1.8 You must provide proof of your purchase of the Bellini product and the date of purchase in order to obtain the benefit of this warranty.
- 1.9 If you live outside the service area of the Company or one of its service agents, this warranty does not cover the cost of transport of the Bellini product for service nor the service agent's traveling costs to and from your home.
- 1.10 If you are required to transport the Bellini product to the Company or its service agent, you must ensure it is safely disconnected by a qualified tradesman and securely packed and insured. The Company does not accept any responsibility for loss or damage of the Bellini product prior to it being received by the Company or its service agent.
- 1.11 You will be responsible for all costs of returning a Bellini product to the Company and for redelivery of the Bellini product by the Company (whether it is the original or a repaired and/or a replacement Bellini product) and for any other expenses you incur in claiming under this warranty.
- 1.12 The Company or its service agent will examine any Bellini product and if the Company determines that it is defective through no fault of the Owner and is otherwise undamaged, the Company will repair or replace the Bellini product in accordance with this warranty.

DO NOT SEND IN THIS WARRANTY

Fill out the following details and file with your purchase invoice.

RETAIN & FILE WITH YOUR RECEIPT

Your Purchase Receipt/Invoice is proof of date of purchase. If you are unable to establish the date of purchase, or if the fault is not covered by this warranty, or if the product is found to be in working order, you will be required to bear all service call charges.

GSM Retail Australia Pty Ltd reserves the right to discontinue items, modify designs and change specifications without incurring obligation.

Whilst every effort is made to ensure that descriptions, specifications and other information in this publication is correct, no warranty is given in respect thereof and the company shall not be liable for any errors therein.

Purchased from:

Co. Name:

Address:

Date of Purchase:

Serial number:

NOTE: Consistent with our continuing product development policy, improvements may have been made which render the contents of this packaging slightly different to that shown.

**FOR WARRANTY SERVICE CALL 1300 373 199 (AUSTRALIA)
OR 0800 764 912 (NEW ZEALAND) TO CONNECT YOU TO THE NEAREST
AUTHORISED SERVICE CENTRE**



Bellini

INSTALLATION & OPERATION INSTRUCTIONS



60cm Built In Oven

Model No.

BOT605BX-F FINELINE: 0013226 NZ Only

BOT605BX

INCLUDED IN BUILDERS PACKS

BPT150EE F/L: 0013228 NZ ONLY

BPT250EG F/L: 0013227 NZ ONLY

BPT350EC F/L: 5104067 AUS/NZ

Thank you

Thank you for choosing Bellini Appliances.

All Bellini appliances carry a 3 year In Home warranty,
be sure to retain your installation and user manual and
receipt.

For all warranty and technical queries please contact

Australia 1300 373 199

New Zealand 0800 764 912

Content

Safety instructions-----	1
Product description-----	3
Installation-----	5
Oven Setting-----	7
Maintenance and cleaning -----	10
Warranty-----	13

This manual explains the proper installation and use of your oven, please read it carefully before using even if you are familiar with the product. The manual should be kept in a safe place for future reference.

General Warnings

- ◆ If the supply cord is damaged, the cord must be replaced by the manufacturer, its service agent or similarly qualified persons in order to avoid a hazard.
- ◆ This product has not been designed for any uses other than those specified in this booklet
- ◆ This appliance must not be used as a space heater.
- ◆ In order to avoid fire, the appliance must be kept clean and vents kept unobstructed.
- ◆ Do not spray aerosols within the vicinity of the appliance during operation.
- ◆ Do not store flammable materials in or under the appliance, e.g. aerosols.
- ◆ Do not line the bottom of the oven with foil or cookware.
- ◆ Always use gloves when handling hot items inside the oven.
- ◆ Always turn the grill off immediately after use as fat left behind may catch fire.
- ◆ Do not leave the appliance unattended when cooking. Oils and fats may catch fire due to overheating or boiling over.
- ◆ Do not put pans weighing over 15Kgs on the opened door of the oven.
- ◆ Do not use the appliance in the event of a technical fault. Any faults must be fixed by an appropriately qualified and authorised person.
- ◆ In the event of any incident caused by a technical fault, disconnect the power and report the fault to the service centre to be repaired.
- ◆ The rules and provisions contained in this instruction manual should be strictly observed.
- ◆ Do not allow anybody who is not familiar with the contents of this instruction manual to operate the appliance.

Child Safety

- ◆ This appliance is not intended for use by persons (including children) with reduced physical, sensory or mental capabilities, or lack of

experience and knowledge, unless they've been given supervision or instruction concerning use of the appliance by a person responsible for their safety.

- ◆ Children should be supervised to ensure that they do not play with the appliance.
- ◆ During use this appliance becomes hot. Care should be taken to avoid touching hot surfaces, e.g. oven door, heating elements.
- ◆ Accessible parts will also become hot when in use. To avoid burns and scalds children should be kept away.

Installation, Cleaning & Servicing

- ◆ The appliance must be installed only by an authorised person in compliance with the instructions provided. Incorrect installation may cause harm to persons, animals or may damage property.
- ◆ Before using the appliance, ensure that all packing materials are removed from the appliance.
- ◆ In order to avoid any potential hazard, the enclosed installation instructions must be followed.
- ◆ Ensure that all specified vents, openings and air spaces are not blocked.
- ◆ The panels adjacent to the oven must be made of heat-resistant material.
- ◆ Cabinets with a veneer exterior must be assembled with glues which can withstand temperature of up to 120°C.

-
- ◆ To reduce the risk of fire, do not place or install this unit in areas where the ventilation or circulation ducts may become blocked. Make sure there are at least 70mm of space between the back of your oven and the wall. Keep some distance on each side of your oven that you can use that distance

following installing instructions.

- ◆ The unit's power cord must be connected to a properly grounded and protected, 220-240V electrical outlet. Always use ground fault protection where required by the electrical code.
- ◆ When transporting or storing the unit, keep it in a dry location, free from dust, excessive vibration or other factors, which may damage the unit.
- ◆ Do not operate oven with a damaged cord, plug or if the oven has malfunctioned or has been dropped or damaged in any manner. Return oven to authorised service facility for repair.
- ◆ Only authorised personnel should carry out servicing. (Certificate of Compliance to be retained)
- ◆ Always ensure the appliance is switched off before cleaning or replacing parts.
- ◆ Do not use steam cleaners, as this may cause moisture build-up.
- ◆ Always clean the appliance immediately after any food spills.
- ◆ **THIS APPLIANCE MUST BE EARTHED.**
- ◆ To maintain safe operation, it is recommended that the product be inspected every five years by an authorised service person.

Oven

- ◆ During use the appliance becomes hot. Care should be taken to avoid touching the hot surfaces inside the oven.
- ◆ Switch the appliance off before removing the oven light glass for globe replacement.
- ◆ To avoid an accident, ensure that oven shelves and fittings are always inserted into the appliance in accordance with the instructions.
- ◆ Do not use the door as a shelf.
- ◆ Do not push down when the oven door is open.

Grill

- ◆ Do not cover the grill insert with foil, as fat built up may catch on fire.
- ◆ Always keep the grill dish clean as any build up may catch on fire.
- ◆ Do not leave the grill on unattended.
- ◆ To avoid fire, ensure that grill trays and fittings are always inserted into the appliance in accordance with the instructions.
- ◆ Do not place thick portions of food under the grill. Foods may curl, catch and ignite.
- ◆ Accessible parts may become hot when grill is in use. Children should be kept away.

Environmental Hints

- ◆ Use the oven efficiently, by cooking many trays of food at the same time.
- ◆ Cook 2 trays of scones, small cakes or sausage rolls at the same time.
- ◆ Select the correct shelf location for food being cooked.
- ◆ Do not open the oven door more than necessary.
- ◆ After the oven is turned off it retains heat for some time.



■ This product must not be disposed together with domestic waste. This product has to be disposed at an authorised place for recycling of electrical and electronic appliances.

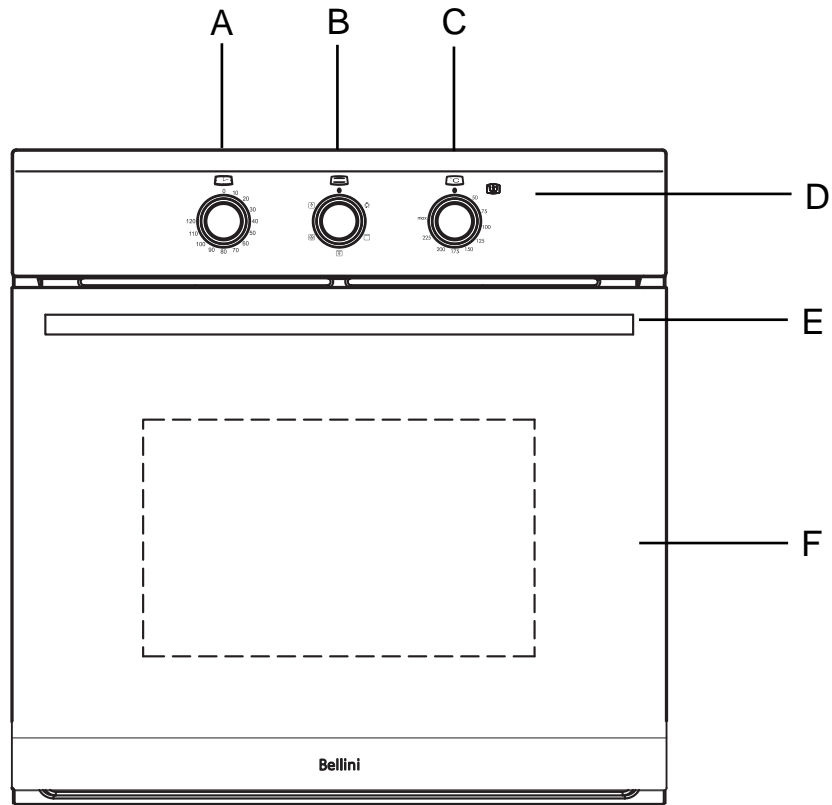

By collecting and recycling waste, you help save natural resources, and make sure the product is disposed in an environmental friendly and healthy way.



- A. Minute Timer Knob
- B. Function Select Knob
- C. Temperature Select Knob

- D. Heating Indicator Light
- E. Handle
- F. 3 Layer Glass Door

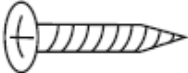
Accessories

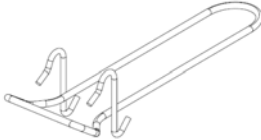
Accessory Name	Picture	Quantity
Mounting Screws(ST4x20)		2 pcs
Baking Pan & Rack		1 Pair
Rack		1 pcs
Tray handle		1 pc

Technical data

model	product dimensions (L x W x D) mm	electrical connection	min. fuse rating	max. power rating	max. current rating
All 2 models	595x596x575	220-240V/50Hz	15A	2.7 – 3.22Kw	13.4A
Heating elements				Motor	
Oven light:	15Watt	Oven inside heating el.	1900 Watt		
		Total grill heating el.	1000+1900 Watt	Shaded motor (back)	25 Watt
		Circle heating el.	2100Watt	Shaded motor (top)	15Watt

WARNING!

Please follow the points below when installing the appliance

Use an Authorised Person

- ◆ Installation should be carried out according to the instructions by a professionally qualified person. The manufacturer declines all responsibility for any damage to persons, animals or things due to a wrong installation.
- ◆ Wiring connections must be in accordance with AS/NZS 3000 Wiring Rules and any particular conditions of the local authority.
- ◆ Refer to data plate for rating information. The data plate is positioned behind the bottom of the oven door. The circuit diagram is positioned on the top panel of the appliance.
- ◆ A functional switch should be provided near the appliance in an accessible position. Refer to AS/NZS 3000 clause 4.7.1
- ◆ Wiring should be protected against mechanical failure. Refer to AS/NZS 3000 clause 1.5
- ◆ A means of disconnection with a contact separation of at least 3mm must be supplied in the fixed wiring. Always turn the grill off immediately after use as fat left behind may catch fire.
- ◆ Unplug the power plug of appliance from socket before installation or any adjustment or maintenance.

This Appliance Must Be Properly Earthed

- ◆ Do not lift the appliance by the door handles.
- ◆ Prepare the cupboard opening to match your appliance measurements. (See diagrams)
- ◆ Slide appliance into the cupboard, ensuring that the supply cable (where fitted) does not kink.
- ◆ To prevent tipping, secure your oven into the cupboard by fastening with 2 screws supplied.
- ◆ Where the appliance is built into a cabinet, the cabinet must be capable of withstanding 70°C. Installation into low temperature tolerant cabinetry (e.g. Vinyl coated) may result in deterioration of the low temperature coating by discoloring or bubbling.

- ◆ The unit panels next to the appliance must be heat resistant. In the case of veneered wood units, glue must be resistant to a temperature of 120°C.
- ◆ If the appliance is to be installed adjacent to vinyl wrapped surfaces, use an installation kit available from the vinyl-wrap supplier.
- ◆ GSM cannot accept responsibility for damage caused by installation into low temperature tolerant cabinets.
- ◆ After installation, test and ensure that the appliance operates correctly before handing it over to the customer.
- ◆ Once the appliance is installed, there must be no possible contact with electrical parts. Any protective parts must can only be removed with the use of tools
- ◆ If a power point is fitted, it must be accessible with the appliance installed, as the plug must be accessible after installation

To avoid any potential hazard, you must follow our instructions when you install your appliance. Failure to install the appliance correctly could invalidate any warranty or liability claims and lead to prosecution.

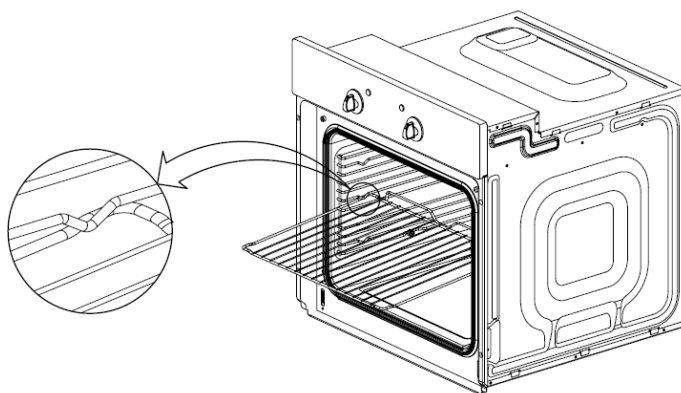
Install the shelf

1. Pay attention to high temperature, you may need to wear gloves if it is hot inside.
2. Always slide shelves into the layer with stopper.

Cabinet Construction For Your Appliance

The sizes of the unit for installing the appliance under a worktop or in a column unit are shown in figure.

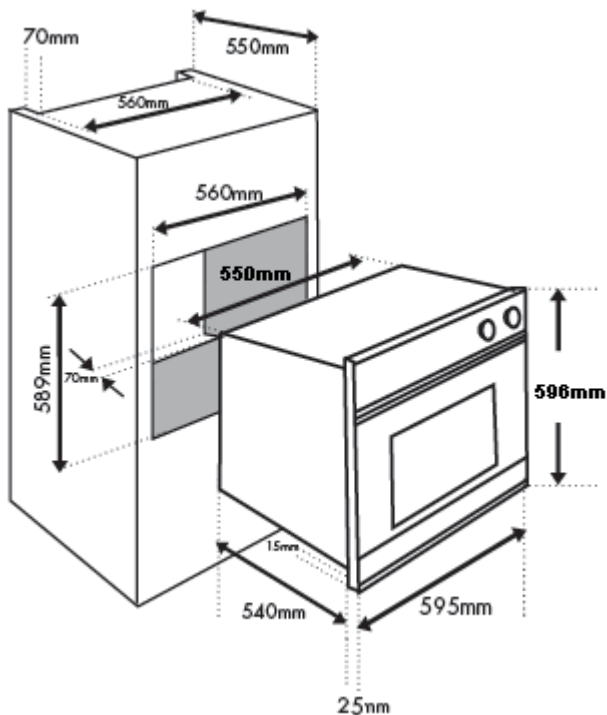
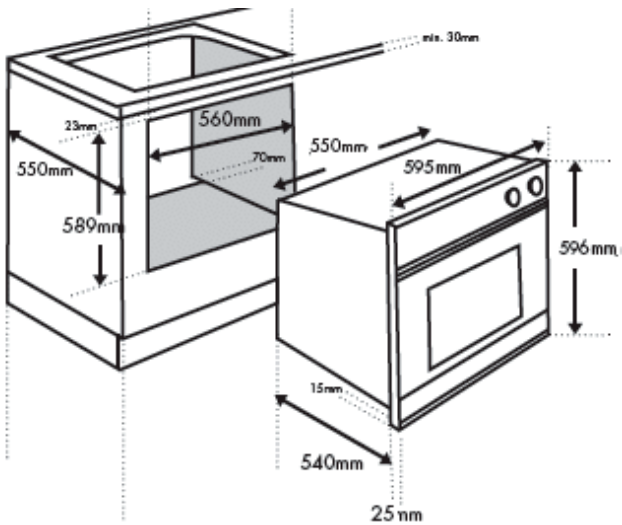

To provide adequate ventilation, there must be appropriate ventilation opening, the panel to which the oven is fitted should have a gap of at least 70 mm at the rear.

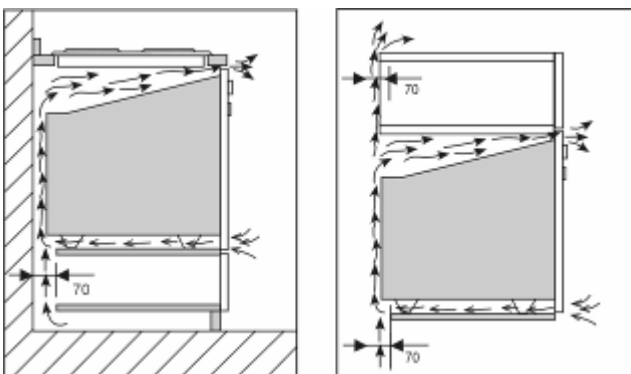

The unit panels next to the appliance must be heat resistant. In the case of veneered wood units, glues must be resistant to a temperature of 120°C.

Fitting Your Appliance

Fit the appliance into its surround (beneath a work-top or above another appliance) by inserting screws into the 2 holes that can be seen in the frame of the oven when the door is open.

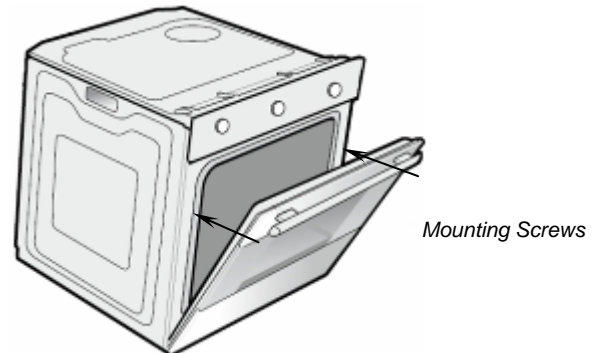

Note:

Your appliance must be mounted on a flat surface for the full width and depth of the product

Connect Power Supply Cord

- ◆ Pull open terminal board cover at rear panel of appliance.
- ◆ Fit wires through on terminal board and make connections to terminals.
- ◆ Engage wires into plastic clip. Secure plastic clip with supplied screws.
- ◆ Close the terminal board cover.

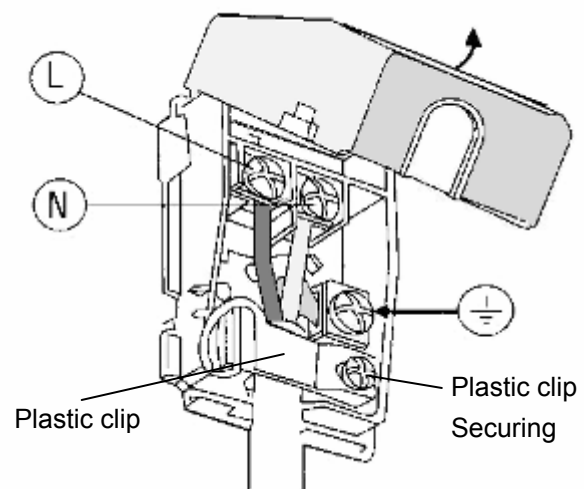

Hard Wired Appliances :

When making the mains supply conductor connections to the terminal block within the terminal box, please ensure that minimum clearances are being maintained between individual conductors and conductors/ connectors to the adjacent metal surfaces of the terminal box itself, where possible add heat shrink sleeves to any bare conductor end/ connectors prior to securing.

Preparing Your Oven

1. Please remove all stickers, leaflets and boxes from the door and from the floor of the oven before operation.
2. Please wipe out the oven interior prior to operation with warm soapy water and polish dry with a soft clean cloth.



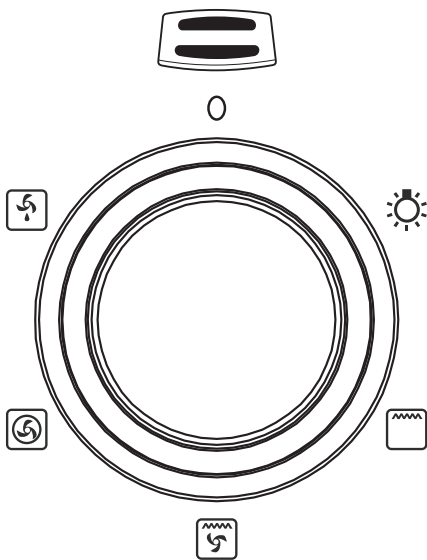

Do not close the oven door until the oven is completely dry.

Select the Functions

Turn the function selector in any direction to the desired function. The oven cavity light will turn on.



Function Selector

function	description
Oven Light 	When the selector knob is in any position other than the "0" position, the oven light comes on.
Defrost 	Select this function, the air at ambient temperature is distributed inside the oven for defrosting food more quickly and without proteins adulteration.
Fan Forced 	Both the fan and the circular heating element operate together. The hot air adjustable between 50°C and MAX°C is evenly distributed inside the oven. This is ideal for cooking several types of food (meat, fish) at the same time without affecting taste and smell. It is ideal for delicate pastries.
Full Grill 	This feature activated all upper heating elements and give rapid cooking to food.
Full Grill + Fan Force 	The air which is heated by the grill heating element is circulated by the fan and so helps to distribute the heat between 50°C and 200°C. This function can be used for sterilizing glass jars.

Select the Temperature

- ◆ To set the temperature, turn the temperature selector in a clockwise direction to the desired setting. An indicator light above the temperature selector will come on.
- ◆ A thermostat controls the temperature in your appliance. When the temperature is reached, the heating source switches itself off and the indicator light goes out. When the oven temperature falls below the desired setting, the heating source switches on and the indicator light comes on again.
- ◆ Once the food is cooked, turn the temperature selector back in an anti-clockwise direction. Do not force it right round in a clockwise direction as this will result in damage to the thermostat.

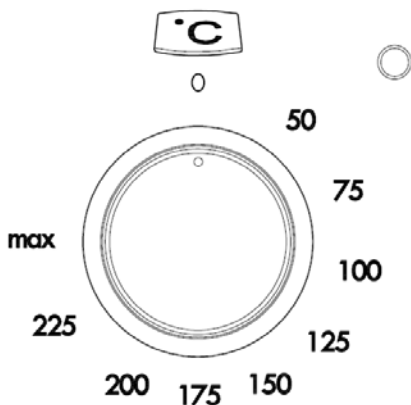

Important

The desired cooking function must be selected before the oven will operate.

Minute Timer

Turn the knob clockwise to set the desired duration. The minute minder can be adjusted from 1 to 120 minutes. An audible signal will sound at the expiry of the set time ,this will NOT switch the oven OFF. Switching the oven OFF has to be manually conducted by turning Function Selection Knob to O

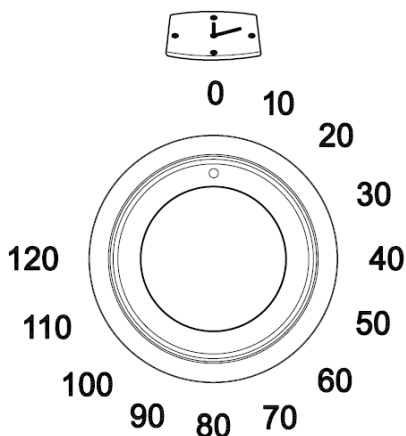

WARNING!

- ◆ Before cleaning your oven, or performing maintenance, disconnect it from the power supply.
- ◆ Do not use steam cleaners.
- ◆ Do not line the oven bottom with aluminium foil, as the consequent accumulation of heat could compromise the cooking and damage the enamel.
- ◆ To protect against the risk of electrical shock, do not immerse the unit, cord or plug in water or other liquid or sprinkle water to clean the appliance!
- ◆ Do not clean the appliance when it is still hot! The inside and external surface of the oven should preferably be cleaned by damp cloth when it is cooled down.
- ◆ Wash all accessories in hot soapy water or in a dishwasher and wipe dry with a paper or cloth towel.
- ◆ If you use your oven for an extended period of time, condensation may form. Dry it using a soft cloth.

Stainless Steel

- ◆ All grades of stainless steel can stain, discolour or become greasy. You must clean these areas regularly by following the procedures below, if you want your appliance to look its best, perform well and have a long life.
- ◆ Care must be taken when wiping exposed stainless steel edges, they can be sharp!
- ◆ The front frame around the oven can be cleaned with stainless steel cleaners if it becomes soiled or discoloured.
- ◆ The stainless steel should only be cleaned with warm water and a mild detergent.
- ◆ Do not use stainless steel cleaners, abrasive cleaners or harsh solvents.
- ◆ Make sure you follow the polish or brushing lines in the steel.

Glass

- ◆ Glass surfaces on doors and control panels are best cleaned immediately after soiling.
- ◆ A damp cloth may help remove baked on food deposits.
- ◆ Oven cleaners can be used to remove stubborn marks and stains.
- ◆ Do not use harsh abrasive cleaners or sharp metal scrapers to clean the oven door since they can scratch the surface, which may result in shattering of the glass
- ◆ Treat glass door gently.

Oven

- ◆ Always keep your appliance clean. Ensure fats and oils do not accumulate around elements, burners or fans.
- ◆ Always keep the oven dish, baking trays and grill dish inserts clean, as any fat deposits may catch fire.
- ◆ Always wrap your meats in foil or an oven roasting bag to minimise cleaning. Any polyunsaturated fats can leave a varnish-like residue which is very difficult to remove.
- ◆ Always keep the grill dish and grill insert clean, as any fat deposits may catch fire.

Replacement of the Oven Light Bulb

WARNING!

In order to avoid the possibility of an electric shock ensure that the appliance is disconnected from the power supply before replacing the bulb.

- ◆ Set all control knobs to the position "•"/"0" and disconnect the mains plug
- ◆ Unscrew and wash the lamp cover and then wipe it dry
- ◆ Unscrew the light bulb from the socket, replace the bulb with a new one—a high temperature bulb (300°C) with the following parameters:
 - voltage 230 V
 - power 15 W
 - thread E14.
- ◆ Screw the bulb in, making sure it is properly inserted into the ceramic socket.
- ◆ Screw in the lamp cover.

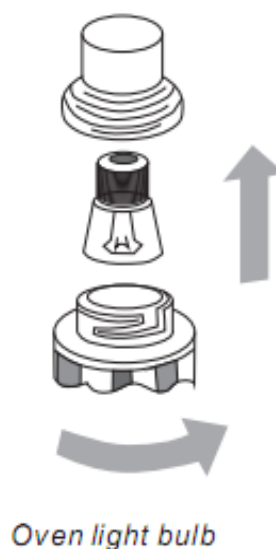

Door Removal

In order to obtain easier access to the oven chamber for cleaning, it is possible to remove the door. To do this, tilt the safety catch part of the hinge upwards. Close the door lightly, lift and pull it out towards you. In order to fit the door back on to the oven, do the reverse. When fitting, ensure that the notch of the hinge is correctly placed on the protrusion of the hinge holder. After the door is fitted to the oven, the safety catch should be carefully lowered down again. If the safety catch is not set it may cause damage to the hinge when closing the door.

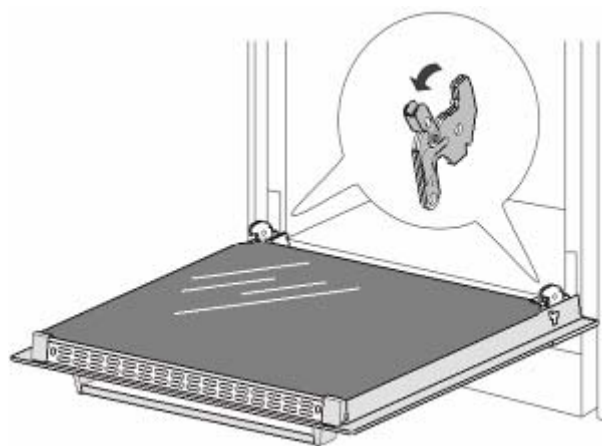

Middle Layer Glass Removal

The oven door is made up of 3 panes of glass and has vents at the top and bottom. When the oven is operating, air is circulated through the door to keep the outer pane cool. If condensation has worked its way in between the glass panes, the door can be dismantled in order to clean in between the panes.

Remove the door as per above instruction and place it on a protective surface (e.g. on a table cloth) to prevent it getting scratched. The door handle should line up with the edge of the table. Make sure the glass lies flat to avoid breakage of glass during cleaning.

1. Undo the 2 screws on upper bracket.
2. Take out upper bracket and first pane of glass.
3. Loosen the 4 clips.
4. Slide out middle pane of glass carefully. Clean the glass panes and other parts with a damp microfiber cloth or a clean sponge and a solution of hot water with a little washing-up liquid. Wipe dry using a soft cloth.

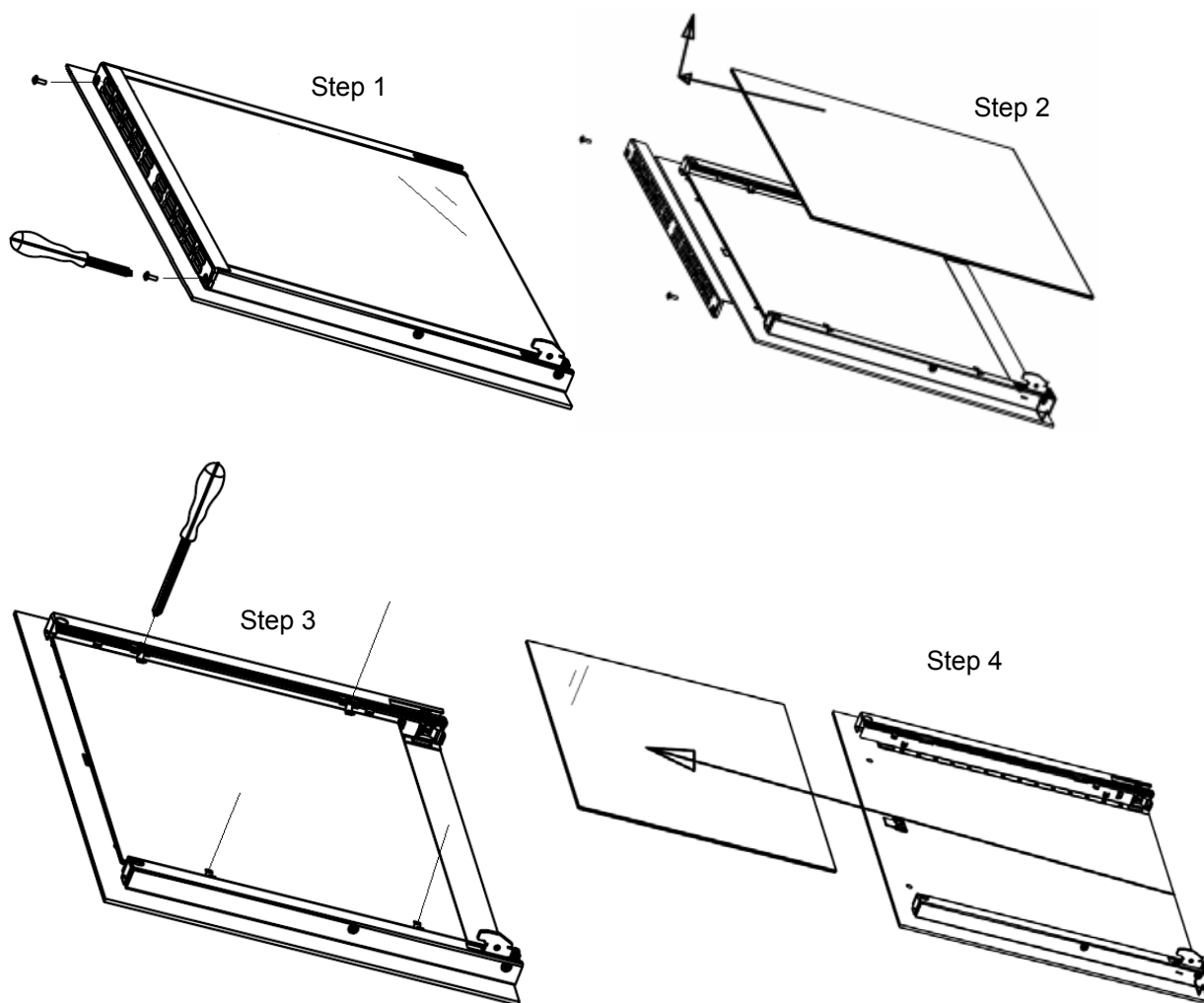

Troubleshooting

Faults	Causes	Remedies
The upper crust is dark and the lower part too pale	Not enough heat from the bottom	<ul style="list-style-type: none"> - Use the natural convection position. - Use deeper cake tins. - Lower the temperature. - Put the cake on a lower shelf.
The lower part is dark and the upper crust too pale	Excessive heat from the bottom	<ul style="list-style-type: none"> - Use the natural convection position. - Use lower side tins. - Lower the temperature. - Put the cake on a higher shelf.
The outside is too cooked and the inside not cooked enough	Too high temperature	<ul style="list-style-type: none"> - Lower the temperature and increase the cooking time.
The outside is too dry even though of the right color	Too low temperature	<ul style="list-style-type: none"> - Increase the temperature and reduce the cooking time.
The appliance does not work	Break in power supply	<ul style="list-style-type: none"> - Check the household fuse box, if there is a blown fuse replace it with a new one.
The oven lighting does not work	Bulb is loose or damaged	<ul style="list-style-type: none"> - Tighten up or replace the blown bulb. (See chapter Cleaning & Maintenance).

*New appliances could have a smell during first use. It is recommended to 'run in' the oven before you cook for the first time. Operate the oven, empty, at a temperature of 180°C for approximately 2-4 hours. Please ensure the room is well ventilated during this process.

WARRANTY

- 1.1 In this warranty:
- 1.1.1 Australian Consumer Law means the law as set out in Schedule 2 of the Competition and Consumer Act 2010;
 - 1.1.2 **Company** means GSM Retail Australia Pty Ltd ABN 53 007 682 475 of 142-144 Fullarton Road, Rose Park SA 5067. Telephone 1300 373 199. Email admin@gsmretailgroup.com
 - 1.1.3 **Consumer** means a “consumer” as that term is defined in Section 3 of the Australian Consumer Law as the original purchaser of a Bellini product;
 - 1.1.4 **Consumer Guarantees** means the guarantees under the Australian Consumer Law;
 - 1.1.5 **You** means the Consumer.
- 1.2 Nothing in this warranty affects any person’s rights under the Australian Consumer Law. The benefits to any Consumer under this warranty are in addition to the rights and remedies available under any Consumer Guarantees.
- 1.3 Subject to the other clauses of this warranty, the Company warrants to the Consumer that the Bellini product will be free of manufacturing defects and will perform to the Company’s specifications.
- 1.4 The benefit of this warranty extends only to the Consumer as original purchaser of a Bellini product which is installed in a domestic household area.
- *The in Home warranty does not apply to Commercial and or industrial usage. *Please See 1.7.7 for additional information*
- 1.5 This warranty commences on the date of purchase of the Bellini product by the Consumer and continues for the benefit only of the Consumer until the expiry of three (3) year **(Warranty Period)**.
- 1.6 If within the Warranty Period a manufacturing defect is discovered in the Bellini product or it fails to perform to the Company’s specifications as a result of some defect in materials, components or workmanship (Defect) then the Company will, at its option, repair the Bellini product or supply a replacement Bellini product free of charge. A replacement Bellini product may differ from the original product purchased by the Consumer.
- 1.7 This warranty will not apply to any Bellini product:
- 1.7.1 Installed by any person other than a qualified tradesperson; or
 - 1.7.2 Subjected to misuse, neglect, negligence or accidental damage; or
 - 1.7.3 Operated in any way contrary to any operating or maintenance instructions; or
 - 1.7.4 Improperly handled, installed or maintained; or
 - 1.7.5 Altered or modified prior to or after installation; or
 - 1.7.6 Damaged directly or indirectly by power surges, electrical storm damage or connection to incorrect power supply
 - 1.7.7 Industrial and or Commercial usage is inclusive of staff areas in office/ shop environments, hotel/ motel or other similar accommodation or rental type properties including Bed and Breakfast establishments.

The Australian Consumer Law requires the inclusion of the following statement with this warranty:

Our goods come with guaranteed that cannot be excluded under the Australian Consumer Law. You are entitled to a replacement or refund for a major failure and for compensation for any other reasonably foreseeable loss or damage. You are also entitled to have the goods repaired or replaced if the goods fail to be of acceptable quality and the failure does not amount to a major failure.

**IN ORDER TO MAKE A CLAIM UNDER THIS WARRANTY THE CONSUMER
MUST CALL 1300 373 199 (AUSTRALIA) OR 0800 764 912
(NEW ZEALAND) TO CONNECT TO THE NEAREST AUTHORISED CENTRE**

- 1.8 You must provide proof of your purchase of the Bellini product and the date of purchase in order to obtain the benefit of this warranty.
- 1.9 If you live outside the service area of the Company or one of its service agents, this warranty does not cover the cost of transport of the Bellini product for service nor the service agent's traveling costs to and from your home.
- 1.10 If you are required to transport the Bellini product to the Company or its service agent, you must ensure it is safely disconnected by a qualified tradesman and securely packed and insured. The Company does not accept any responsibility for loss or damage of the Bellini product prior to it being received by the Company or its service agent.
- 1.11 You will be responsible for all costs of returning a Bellini product to the Company and for redelivery of the Bellini product by the Company (whether it is the original or a repaired and/or a replacement Bellini product) and for any other expenses you incur in claiming under this warranty.
- 1.12 The Company or its service agent will examine any Bellini product and if the Company determines that it is defective through no fault of the Owner and is otherwise undamaged, the Company will repair or replace the Bellini product in accordance with this warranty.

DO NOT SEND IN THIS WARRANTY

Fill out the following details and file with your purchase invoice.

RETAIN & FILE WITH YOUR RECEIPT

Your Purchase Receipt/Invoice is proof of date of purchase. If you are unable to establish the date of purchase, or if the fault is not covered by this warranty, or if the product is found to be in working order, you will be required to bear all service call charges.

GSM Retail Australia Pty Ltd reserves the right to discontinue items, modify designs and change specifications without incurring obligation.

Whilst every effort is made to ensure that descriptions, specifications and other information in this publication is correct, no warranty is given in respect thereof and the company shall not be liable for any errors therein.

Purchased from:

Co. Name:

Address:

Date of Purchase:

Serial number:

NOTE: Consistent with our continuing product development policy, improvements may have been made which render the contents of this packaging slightly different to that shown.

**FOR WARRANTY SERVICE CALL 1300 373 199 (AUSTRALIA)
OR 0800 764 912 (NEW ZEALAND) TO CONNECT YOU TO THE NEAREST
AUTHORISED SERVICE CENTRE**

